

# ASSEMBLY INSTRUCTION FOR MDF6688-2D-1DRW-WR-W

**Note:**

- Read Instructions carefully
- Carefully identify each component especially those that are similar
- Separate and identify each component from the hardware pack and rest each one in its proper location before fastening
- Do not over tighten the screws or bolts when assembling



4 Persons

**TOOL REQUIRED**



**STEP 1**

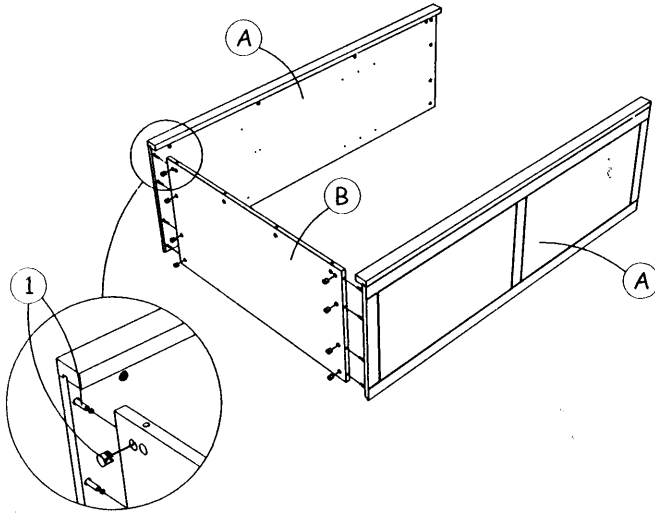

Fix side panel L/R 'A' and top panel 'B' with mini fix '1' as shown.

**STEP 2**

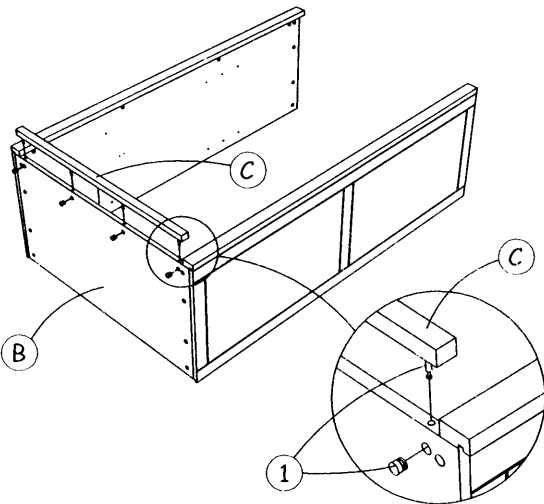

Fix top lining 'C' to the top panel 'B' with mini fix '1' as shown.

**STEP 3**

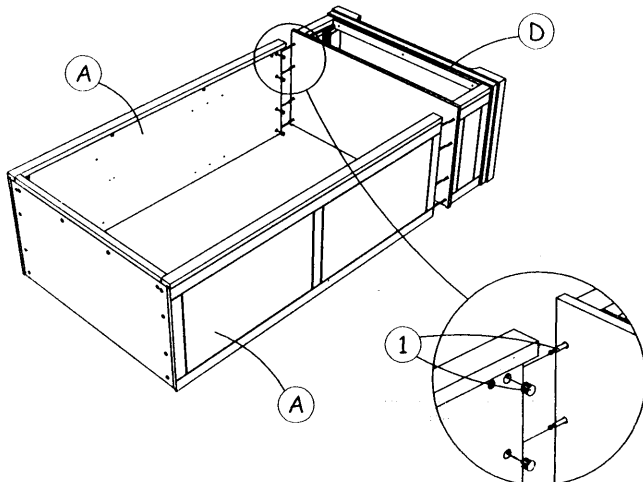

First remove the drawer and fix drawer box 'D' to the side panel L/R 'A' with mini fix '1' as shown in diagram.

**STEP 4**

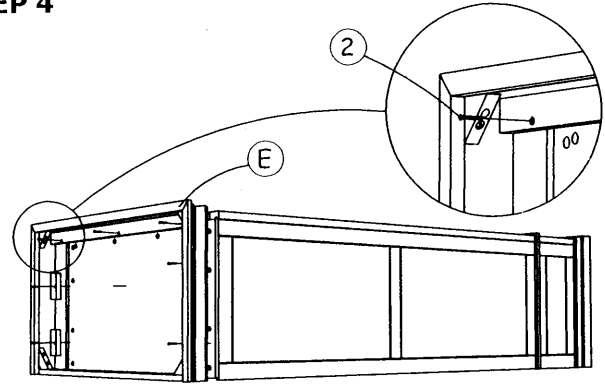

Fix top crown 'E' with screw '2' as shown in diagram.

**STEP 5**

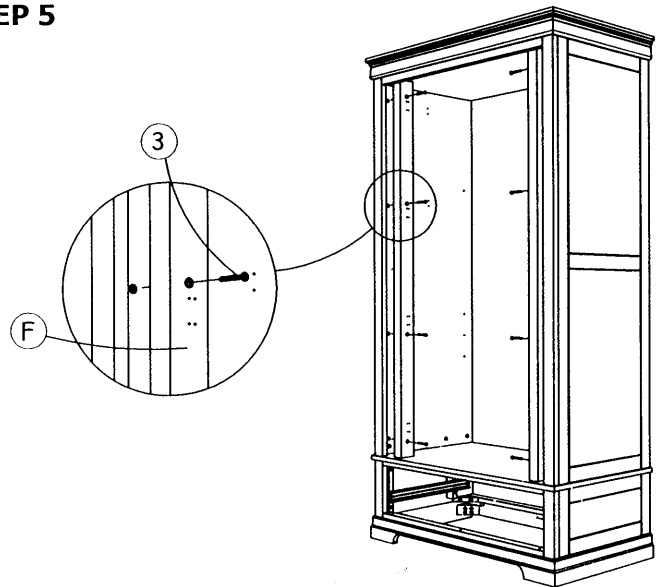

Fix hinges wood 'F' to the side panel L/R 'A' with JCBC '3' as shown in diagram.

**STEP 6**

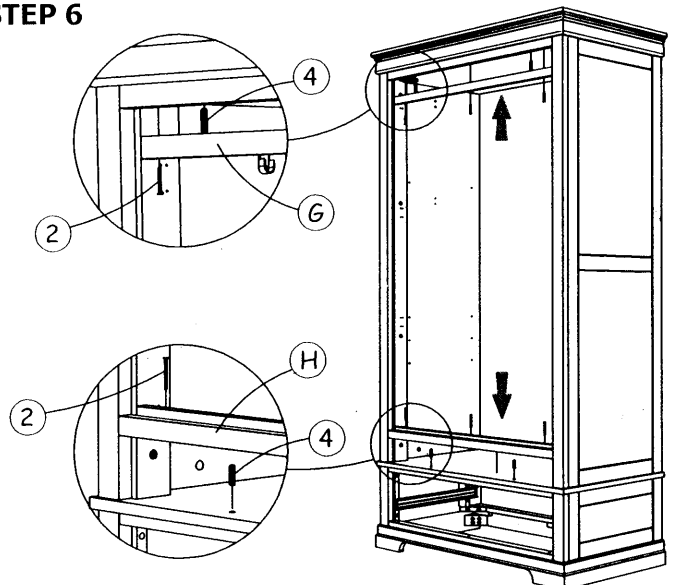

First fix top front support 'G' to the top panel 'B' with screw '2' and wood dowel '4' and fix bottom lining & bottom front support 'H' to the drawer box with screw '8' and wood dowel '4' as shown.

**Please follow our assembly instruction procedure for easier assemble.**

### STEP 7

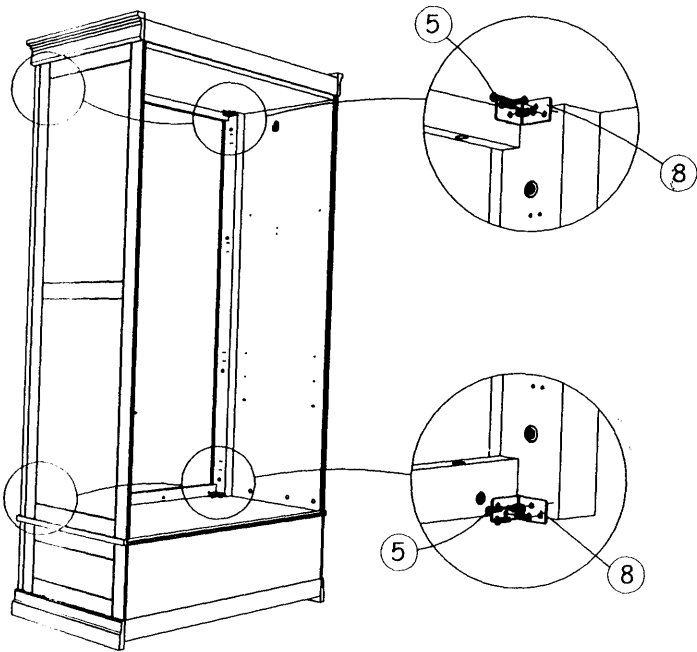

Fix L bracket '8' with screw '5' as shown.

### STEP 9

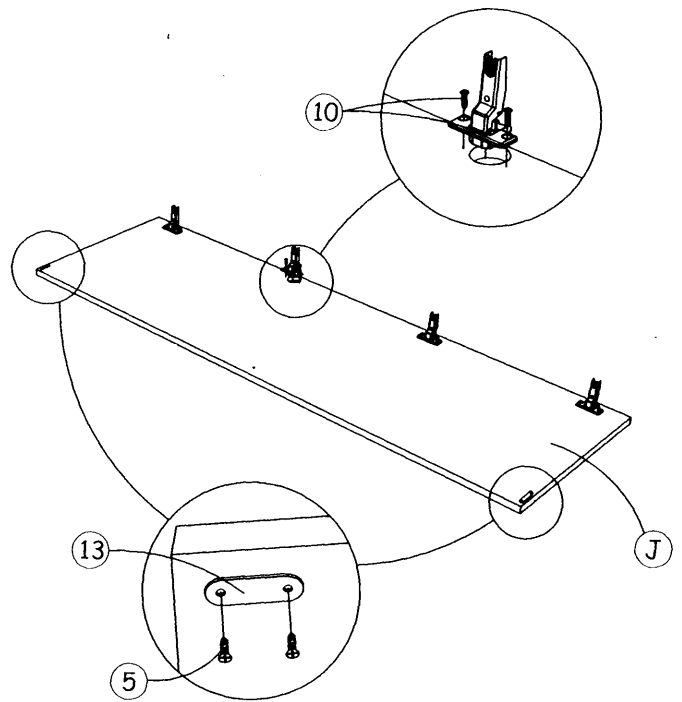

Fix hinges '10' to the door 'J' and fix magnet stopper '13' with screw '5' as shown

### STEP 8

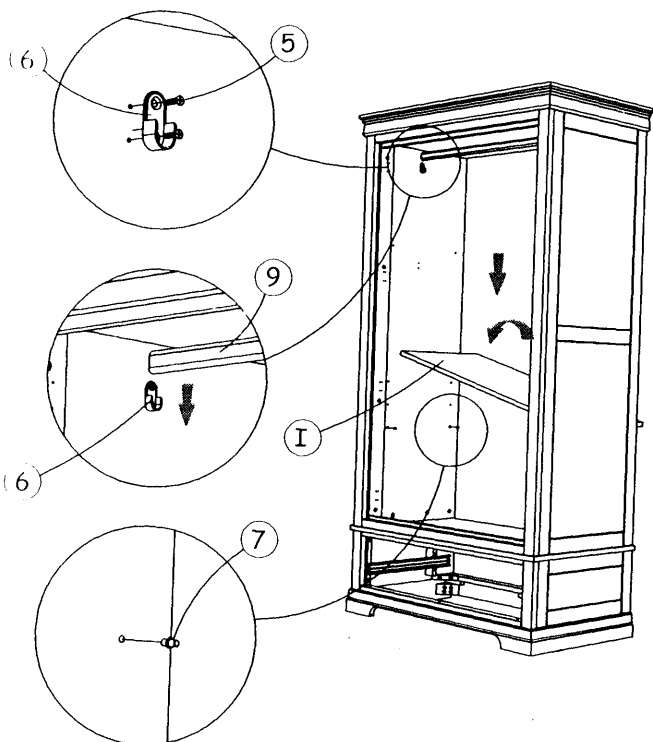

Fix U bracket '6' with screw '5' and fix iron stud '7' to the side panel L/R 'A' and than put hanging rod '9' to the U-bracket '6' as shown.

### STEP 10

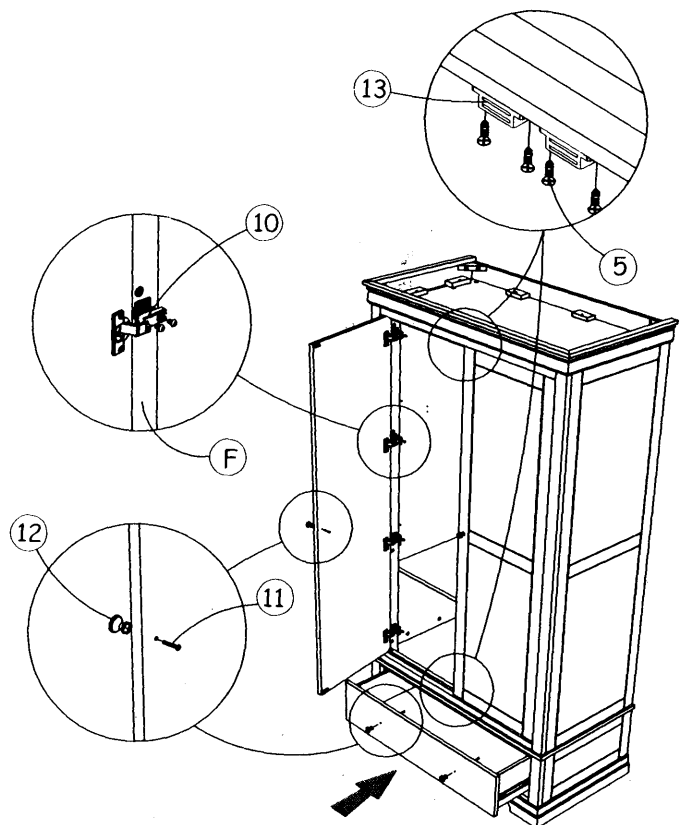

First fix the door 'J' to hinges wood 'F' After that fix door handle '12' with screws handle '11' and than fix magnet stopper '13' to the door 'J', top front support 'G', bottom lining & bottom front support 'H' with screw '5'. At last put back the drawer into the bottom box and make sure all bolts, mini fix and screws are tighten.

**Please follow our assembly instruction procedure for easier assemble.**

## STEP 11

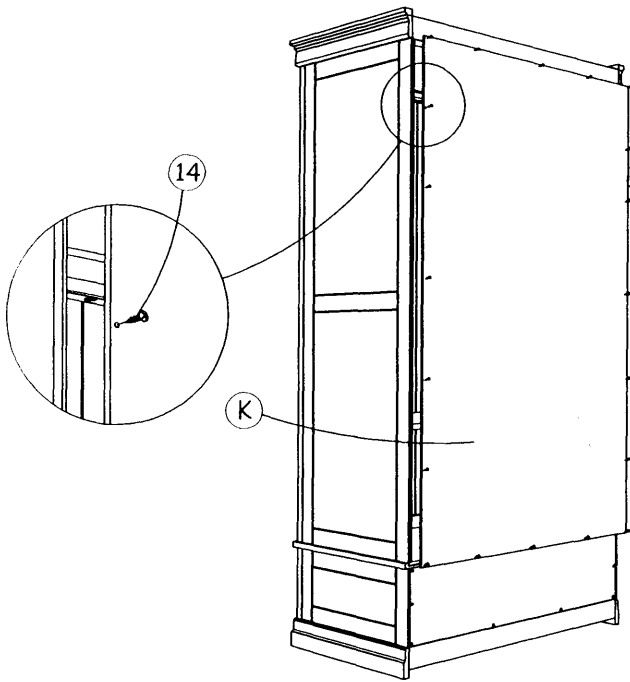

Fix back panel 'K' with pan head screw '14'. Before assemble the back panel, please ensure minifix already locked.

## STEP 12

Step 1, please loosen this screw for adjust the door.

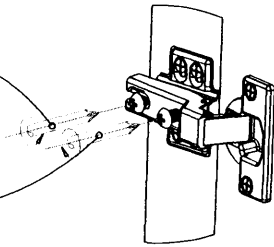

Step 2, please twist this screw follow clock for adjust the door inside

Step 3, please twist this screw versus clock for adjust the door outside

Step 4, please tide again this screw after you confirm the door position that you wanted.

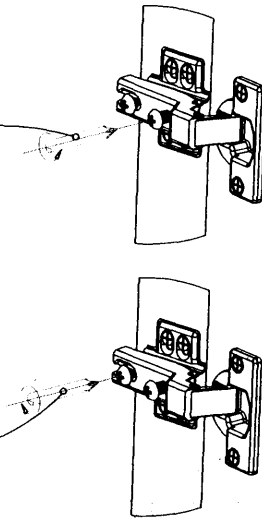





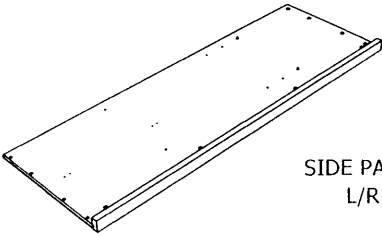
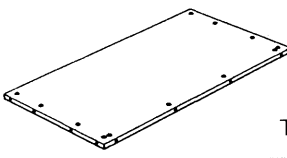
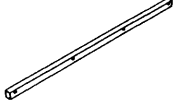
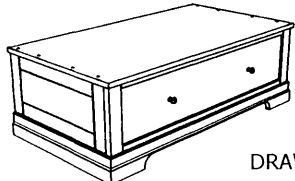
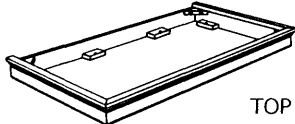
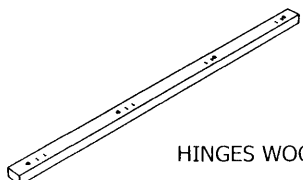
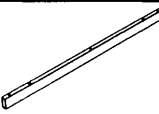
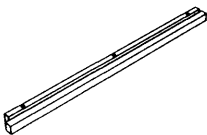
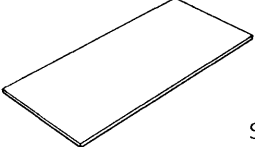
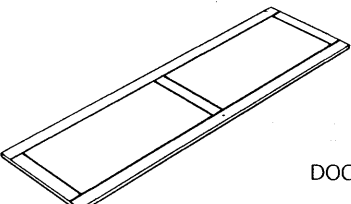

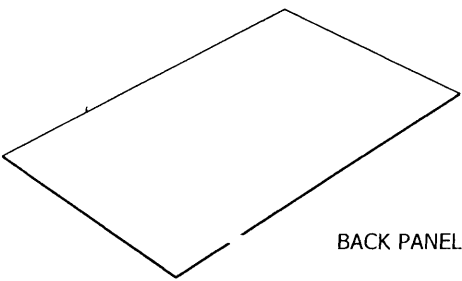

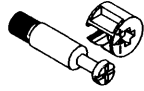



**Please follow our assembly instruction procedure for easier assemble.**

# HARDWARE & PART LIST FOR MDF6688-2D-1DRW-WR-W

NO.	PART	QTY.
A	 SIDE PANEL L/R	2 PCS
B	 TOP PANEL	1 PC
C	 TOP LINING	1 PC
D	 DRAWER BOX	1 SET
E	 TOP CROWN	1 PC
F	 HINGES WOOD L/R	2 PCS
G	 TOP FRONT SUPPORT	1 PC
H	 BOTTOM LINING & BOTTOM FRONT SUPPORT	1 PC
I	 SHELF	1 PC
J	 DOOR	2 PCS

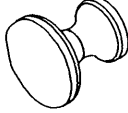
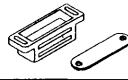
K	 BACK PANEL	1 PC
---	---	------

NO.	HARDWARE	QTY.
1	 MINI FIX	20 PCS
2	 CSK SCREW #4 x 30mm	22 PCS
3	 JCBC BOLT M6 x 50mm	8 PCS
4	 WOOD DOWEL M8 x 30mm	4 PCS
5	 CSK SCREW #3.5 x 16mm	32 PCS
6	 U-BRACKET (B3428)	2 PCS
7	 IRON STUD	4 PCS
8	 L BRACKET HW-BKT-L-025	4 PCS
9	 HANGING ROD	1 PC
10	 HW-HGS-SOFT-C-A01 C/W SCREW (2 PCS/ SET)	4 SETS
11	 SCREW HANDLE M4 x 22mm	2 PCS
12	 HANDLE B302	2 PCS
13	 MAGNET STOPPER	4 PCS
14	 PAN HEAD SCREW #3.5 x 16mm	20 PCS
15	 M6 - ALLEN KEY	1 PC